



MAGNETIC SENSORS CORPORATION
Measuring the Rate of Progress Since 1983

EXPLOSION PROOF SENSORS :
CSA/ATEX Certified

Variable Reluctance Speed Sensor
Part Number: 401035-00

Description:

- Safe for hazardous environments, such as methane gas, and flammable liquids
- Perfect for refinery, chemical and other potentially explosive applications
- Ready for immediate delivery
- Operating temperature range -40° to 212° F
- Available in a variety of sizes and mounting thread options
- Can be customized with additional certification

Applications:

- Oil Refineries
- Chemical Companies
- Marine
- Power Generation



ATEX/IECEx certified explosion proof magnetic speed sensors for Class I, Division 1, Group A, B, C, & D hazardous areas. Designed for use in atmospheres containing acetylene, flammable gas, flammable liquid-produced vapor, or combustible liquid-produced vapor.

SENSOR SPECIFICATIONS				TEST SPECIFICATIONS	
NOM. RESISTANCE	180 OHMS ± 10% @ 78°F	HOUSING MATERIAL	303 S.S.	OUTPUT VOLTAGE	54 V MIN. PEAK TO PEAK AT THE FOLLOWING CONDITIONS
INDUCTANCE	60 mH REF	OVERALL LENGTH	1.867 in ± .020 in	SURFACE SPEED	1000 I.P.S
OPERATING TEMPERATURE	-40° C to 100° C	WIRE	18 AWG	TEST WHEEL	8 PITCH GEAR FERROUS MATERIAL
DIELECTRIC STRENGTH	1000 V	MOUNTING THREAD SIZE	3/4-20 UNF 2A THREAD	AIR GAP	0.005 in
POLARITY	WHITE LEAD POSITIVE WITH RESPECT TO BLACK WITH THE APPROACH OF FERROUS TARGET	CONNECTOR	N/A	LOAD RESISTANCE	100 K OHMS

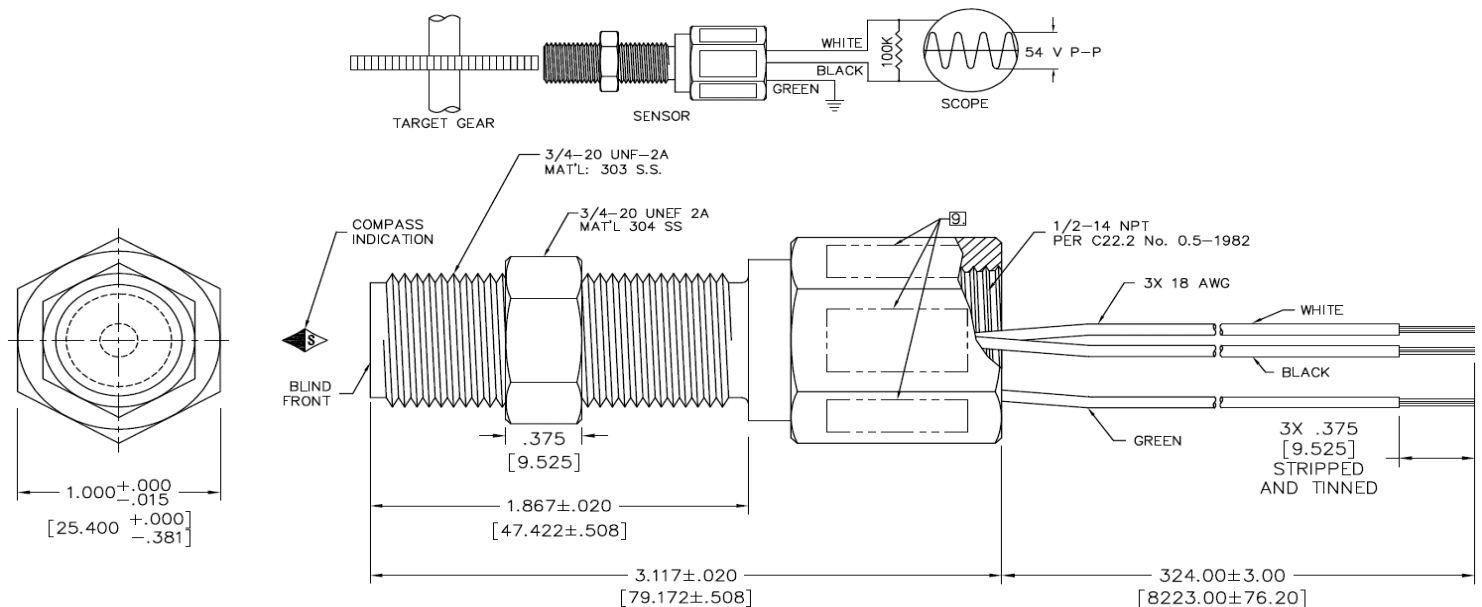

Additional Part Numbers of our ATEX units by threadsize

3/4-20	401092-40	5/8-18	401031-80	401033-40
	401034-80		401033-10	401034-30
			401033-30	

